

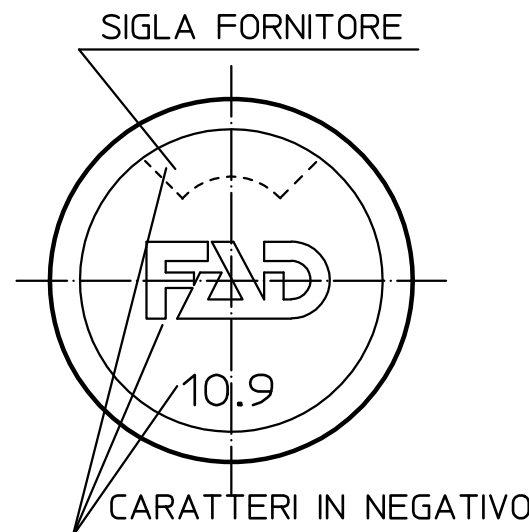

Proprietà riservata. - Questo disegno non può essere utilizzato o riprodotto senza nostra autorizzazione.
 This print is provided on a restricted basis and is not to be used in any way detrimental to our interests.

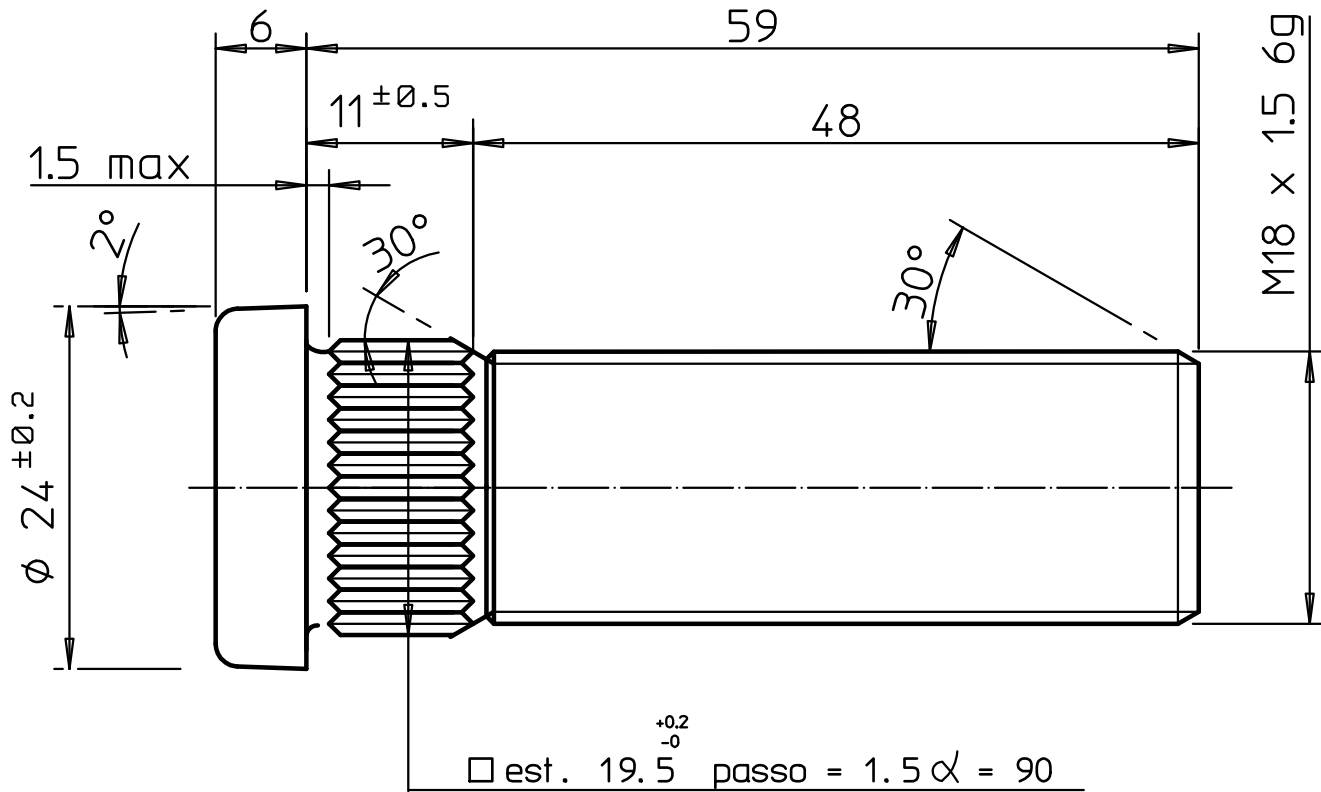

TRATTAMENTO SUPERFICIALE : ZINCATURA TIPO Fe/Zn 5

NOTE: _____

MATERIALE - MATERIAL - MATIERE - WERKSTOFF UNI		PROGETTO - PROJECT ENTWURF		PESO - WEIGHT PODS - GEWICHT	
CLASSE 10.9 3740-75		CLASSE 10.9 267			
DENOMINAZIONE - DENOMINATION - DESIGNATION - BENENNUNG		SCALA - SCALE ECHELLE - MASSTAB		DATA - DATE - DATUM	
COLONNETTA M18 x 1.5 x 59		2:1		24-05-90	
		DISEGNATO - DRAWN DESSINE - GEZEICHNET		VISTO - APPROVED VERIFE - GEPRUFT	
		Bellandi			

GKN FAD SPA
 CARPENEDOLO - Brescia
 ITALY
 DIS. - DRG. - PLAN - ZEICHG.
309F009

D	RIPRISTINATO SIMBOLO FAD	(33124)	02-11-06	Bondiali	VISTO
C	VARCLASSE RESIST. E RIVEST.SUPERFIC.(ERANO 8.8 E BRUNITA+OLEATA)	(33089)	17-10-06	Bondiali	APPROVED
B	VARIATO SIMBOLO FAD IN GKN	(032271)	18-04-06	Magalini	VERIFE
A	VARIATO MATERIALE DA 10.9 A 8.8		30-04-93	Bellandi	
			DATA	DATE	DATUM
			MODIFICA - MODIFICATION - ANDERUNG		

S-05.3/4